An interoperable framework for Intellectual Property Rights using web ontologies

Rosa Gil

Universitat Pompeu Fabra
rosa.gil@upf.edu

Roberto García

Universitat Pompeu Fabra
roberto.garcia@upf.edu

Jaime Delgado

Universitat Pompeu Fabra
jaime.delgado@upf.edu

abstract

In order to improve the management of Intellectual Property Rights (IPR) in Internet, there is the need for a common language for IPR representation. This language is aimed to help building a reliable Web where IPR can be managed in an open, global and adaptable form, so people can share, sell, buy, etc. content subject to IPR, depending on their needs.

We are following a semantic approach to this problem, based on semantic web ontologies, that seems more appropriate than a syntactic one, e.g. based on XML. IPROnto, the IPR ontology we have developed, puts this approach into practice. IPROnto models the IPR core concepts for content, intellectual property rights and the basic kinds of actions that operate on intellectual property and allow developing licenses. IPROnto enables semantics-aware IPR applications that benefit from semantic queries, in contrast to the difficulties that emerge from the use of syntactic queries when the information space is as complicated as in the IPR field. Moreover, specialised reasoners can be used for license checking and retrieval.

All these advantages have been propagated to the main syntactic approaches to IPR management (MPEG-21 and ODRL). We have applied XML Schema to OWL and XML to RDF tools in order to facilitate mapping these initiatives to IPROnto. Once mapped, syntactic initiatives can also benefit from the semantic approach provided by Web ontologies.

1. Introduction

Our objective is to make a new contribution to the Intellectual Property Rights (IPR) management research field. There are different initiatives trying to solve the problem of interoperability between Digital Rights Management (DRM) systems, which have started from isolated and proprietary initiatives. However, they are lately clearly moving to a web-broad application domain.

One of the main initiatives is MPEG-21 (Walle, R.v.d. 2005), a MPEG standardisation framework for digital contents management. MPEG's IPR modelling part is divided into the Rights Expression Language (REL) (Wang, X. 2005) and the Rights Data Dictionary (RDD) (Rust, G. 2005).

Another initiative is ODRL (Open Digital Rights Language), developed by IPRSystems and available also as W3C note (Iannella, R. 2002), that has been adopted by OMA (Open Mobile Alliance).

There are many other initiatives but, basically, all have one thing in common, they work at the syntactic level. Their approach is to define some XML Schemas that define rights expression languages (REL). In some cases, the semantics of these languages, the meaning of the expressions, are also provided but formalised separately as rights data dictionaries (RDD). Rights dictionaries list terms definitions in natural language, solely for human consumption and not easily automatable.

However, the syntactic approach does not scale well in really wide and open domains like the Internet. An automatic processing of a huge amount of metadata coming from many different sources requires machine understandable semantics. The syntax is not enough when unforeseen expressions are met. Here is where semantics come to help their interpretation to achieve interoperation.

Our idea is to facilitate the automation and interoperability of IPR frameworks integrating both parts, the Rights Expression Language and the Rights Data Dictionary. These objectives can be accomplished using ontologies, which provide the required definitions of the rights expression language terms in a machine-readable form. Thus, from the automatic processing point of view, a more complete vision of the application domain is available

1

Bernd
Vrie
Ror
ld
Lee
es,
Joh
Zeli
nikk
-
Mer
ng
the
fuss

and more sophisticated processing can be carried out.

We have taken the Semantic Web approach (Berners-Lee, T. 2001) because it is naturally prepared for the Internet domain and thus we use web ontologies (Hendler, J. 2001). The modularity of web ontologies, constituted by concept and relation definitions openly referenceable as URIs, allows their easy extension and adaptation to meet evolvability and interoperability.

Once we decided our approach, the ontology creation process, detailed in the next section, was initiated. We did not start from scratch. Firstly, a clear definition of the IPR domain was searched. We decided that results from <indec> (Rust, G. 2000) and Imprimatur (Barlas, C. 1998) projects were a suitable starting point because of their coverage in describing this domain, so the terms definitions and their structure were adopted and formalised using web-ontology tools. This was complemented with previous work in our research group, DMAG¹.

Moreover, in order to concretise IP legal aspects, we have used the World Intellectual Property Organisation² recommendations, which try to define a common worldwide legal framework for IPR. On the other hand, we have tried to be agnostic in relation to upper level concept. Therefore, we have been not bounded to any upper level ontology during the IPRonto development. Our intention is to keep in mind some top ontologies in order to make IPRonto, once completed, alignable with as many upper ontologies as possible. In section 2 there is a more detailed explanation of the ontology development.

A preliminary version of IPRonto³ was contributed (Delgado, J. et al. 2001) to MPEG-21 REL-RDD call for proposals⁴. As it has been explained before, MPEG-21 selected a syntax-oriented approach with separated REL and RDD. Another example of use of the semantic approach for IPR representation is the Harmony project (Hunter, J. 2003).

We have continued working with IPRonto with satisfactory results. Our current work focuses on showing how IPRonto can interoperate with other initiatives, MPEG-21 REL-RDD and ODRL, and facilitate complicated tasks like IPR licenses validation and negotiation, thanks to the formal seman-

tics that IPRonto can provide to this syntactic initiatives. More details are given in section 3.

2. Developing the IPR Ontology

Although there is not an established ontology development methodology (Fernández-López, M. 1999), we have tried to adapt one of the existing ones that we found more appropriate, Methontology (Fernández-López, M. 1997). The ontology life cycle Methontology describes, evolving prototypes, has driven IPRonto development.

For the development process, we followed the basic steps: conceptualisation, formalisation and implementation. The requirements have been depicted in the introduction and this first step served to detect the candidate knowledge sources. During formalisation, the knowledge sources have been studied and the models that are shown next have been built.

Finally, formalization and implementation has been automatized using ontology development tools. The objective has been to produce computable models based on Semantic Web languages. OWL is used for ontologies and SWRL (Horrocks, I. 2004) for rules. More details about the whole process are given in the next subsections. A graphical poster representation of IPRonto is available at (Delgado, J. et al. 2002). It is based on a previous version but it might be useful in order to visualise how it looks like.

2.1. Creation Model

The core concepts of IPRonto are those that formalise the notion of creation. As we can see in Figure 1, there are three points of view of a creation: the abstraction, manifestation and expression perspectives.

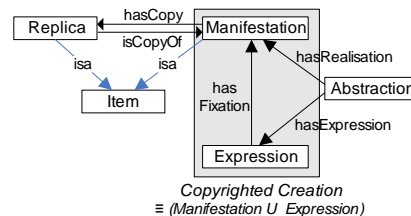

Figure 1. Creation model showing different views on creation

For instance, if we take the creation “Les Misérables”, we can observe it from these three perspectives taking different forms. From the object view, we can see a script, a book, etc. Its film projection would be seen from the event perspective. All have in common the original Victor Hugo’s idea visible from the abstraction perspective.

The ideas cannot be copyrighted so they lay outside the copyrighted creation concept. Abstraction, on the other hand, is what we grasp as common in different manifestations, expressions or replicas and what allows us saying that they are the same creation.

2.2. Rights Model

From the legal point of view, WIPO recommendations have been followed and the intellectual property rights they define are present in IPROnto. Table 1 shows the included rights hierarchy starting from Copyright. There are also other intellectual property rights that are not shown, e.g. sui-generis rights, neighbor rights, etc. although they are unimportant in this context.

The more important rights in the Digital Rights Management context are Exploitation Rights as they are related to productive and commercial aspects of intellectual property. Each of these rights defines a set of actions that can be done or not on a creation depending on the rights situation:

- *Transformation Right*: grants actions of type transform that produce a new creation, like adapt, translate, subtitle, etc.
- *Communication Right*: grants actions of type communicate, like broadcast, perform, make available (e.g. on the Internet), etc.
- *Distribution Right*: grants actions of type distribute, like sell, rent, etc. This right, and consequently the kind of actions it includes, only affects manifestations of a creation (e.g. compact disk, DVD, cassette, etc.).
- *Reproduction Right*: grants actions of type reproduce, like copy, fix (an expression into a manifestation, e.g. an opera into a CD), etc.

Moral rights are always hold by the creator and cannot be commercially exploited. Moreover, they are only fully considered in Continental-like IPR systems, i.e. legal system like those in the Euro-

pean Union. On the other hand, legal systems of the Anglo-Saxon kind do not consider them. Therefore, as they do not have commercial interest, moral rights are modelled but not detailed in IPROnto for the moment.

Copyright

MoralRight

DisseminationRight
 PaternityRight
 RespectRight
 WithdrawalRight

ExploitationRight

TransformationRight
 AdaptationRight
 TranslationRight
 SubtitlingRight

CommunicationRight
 BroadcastRight
 PublicPerformanceRight

DistributionRight
 RentalRight

ReproductionRight
 FixationRight

Table 1. Copyright hierarchy

We can also identify two more kinds of actions that are related to intellectual property, although the mentioned rights do not cover them:

- *Transfer*: these are actions to move rights between rights holders and are related to the exploitation aspect of intellectual property rights, only exploitation rights can be transferred. End users do not hold rights so there are no transfers to them. There are also commercial actions, which are related to transfer actions. Commercial actions are offer, agree, counteroffer, post-agree, etc.
- *Use*: end users do not hold exploitation rights. They just consume creations, i.e. they use them. Uses are not covered by copyright. However, this does not mean that end users can do whatever they want, they should not realise actions that require copyright. Moreover, they might be subject to special conditions under which they have acquired the permission to use a creation (e.g. a film that

Bernd
 Vrie
 Ror
 Id
 Lee
 es,
 Joh
 Zeli
 niki
 -
 Mer
 ng
 the
 fusi

can only be viewed a fixed number of times and thus is cheaper than a DVD reproduction).

The previous actions are associated to the different roles that take part in the creation' life cycle. Or, from the commercial point of view, it can be seen as the creation's value chain. Legal persons play roles. Actions are shown as arrows in Figure 2. The ovals represent the different roles; those at the source of the arrows perform the actions. The arrow destinations show the role that receives the responsibility over the creation once the action has been performed.

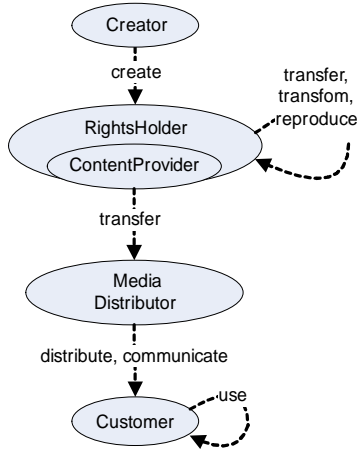

Figure 2. Creation life cycle

First of all, the creator acts and a new creation is produced. Automatically, there is a holder that gets rights on the creation. The ovals represent roles that might be played by the same person. Therefore, the rights holder can be the same person that acted as creator.

Then, the rights holder can transfer all or a portion of the rights to a content provider. Content providers are specialised in transforming raw creations in order to facilitate their commercialisation. Moreover, if the creation is commercialised physically, they are responsible for reproducing the creation in order to produce the replicas for consumption.

Next, it is time to make the creation available to end-users. Media distributors are responsible for this part. They get a transfer of the rights they need for the distribute and communicate actions, which

are the actions that make creations available for end users.

Finally, at the end of the life cycle or value chain, the customer uses the creation in order to consume it.

2.3. Action Model

As it has been shown, IPRonto takes Intellectual Property (IP) rights into account but it has actions as its central building block, where actions are those covered by exploitation rights but also usage and transfer ones. With them, we try to cover all the events in the value chain.

Actions are not isolated entities, they are related to a bunch of entities that take part or are affected by the action. Moreover, there are space-time coordinates that situate the action. One thing that all actions have in common is that they are verbs. Therefore, in order to facilitate their modelling, we have incorporated into IPRonto ideas from the linguistics field related to the classification of verbs and their relation to other linguistic components.

These relations are called thematic roles or case roles (Sowa, J.F. 2000) and are classified into initiator, resource, goal and essence. In Table 2 we show at the top the case roles we have considered in IPRonto and also the kinds of verbs they are related to. These kinds of verbs define verbs facets, not disjoint classes of verbs, and concretise the general thematic roles as shown in each row. Therefore, the same verb can present one or more of these facets. For instance, the play verb can show the action, temporal and spatial facets in a particular sentence.

	initiator	resource	goal	essence
Action	agent, effector	instrument	result, recipient	patient, theme
Process	agent, origin	matter	result, recipient	patient, theme
Transfer	agent, origin	instrument, medium	experiencer, recipient	theme
Spatial	origin	path	destination	location
Temporal	start	duration	completion	pointInTime
Ambient	reason	manner	aim, consequence	condition

Table 2. Case roles

Figure 3 shows an example of action modelling using thematic roles to relate the verb to its participants and context. In this case it is a reproduction of a master copy to produce CDs. It is done using a computer and is completed in 2000.

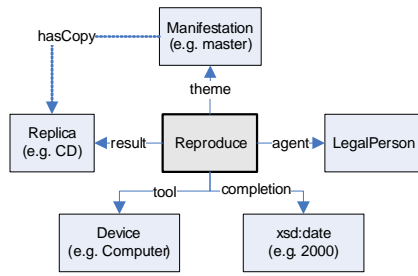

Figure 3. Action modelling example using thematic roles

2.4. Upper ontologies

To conclude, IPROnto is enriched with general concepts for time, space, tools, part hood, etc. They are taken from upper level ontologies, which define general concepts. For the moment, we have considered some upper ontologies: IEEE SUMO (Pease, A. 2002), DOLCE (Gangemi, A. 2002) and LRI-Core (Breuker, J. 2004). Our intention is to make general concepts reused from upper ontologies interchangeable and make alignment of IPROnto to all these top ontologies possible.

3. IPROnto into practice

Traditionally, DRM Systems (DRMS) have dealt with the rights management problem for bounded domains. However, when scaled to the Web, DRMSs are very difficult to develop and maintain. The solution is interoperability of DRMS, i.e. common frameworks for understanding with shared languages and vocabularies.

As it has been said, the aim of this work is to construct a framework for the fair and open exploitation of intellectual property rights. It has been discussed that, from our point of view, pure syntactical approaches lack the needed flexibility and expressiveness to cope with a so complex and sensible domain as the IPR one.

We propose an ontology framework, IPROnto, based on a formalisation of IPR legal concepts, not a formalisation of syntax to express them some-way. Thus, it is based on the domain semantics and, given that we also conceive it founded on openness, we have tried tools from the Semantic Web initiative.

URI, RDF, web ontologies and other Semantic Web facilities have been used in order to construct an open, extensible and adaptable IPR ontology.

Our objective now is to integrate IPROnto with syntactic rights expression languages like MPEG-21 REL-RDD and ODRL. IPROnto can benefit from this integration because new requirements are being detected in order to make IPROnto more complete. Moreover, IPROnto can contribute formal semantics to these initiatives. We have started to show that this can facilitate implementing MPEG-21 and ODRL applications. We give more details in the next sections.

3.1. ODRL integration with IPROnto

ODRL is one of the main rights expression languages. It is based on a XML language defined by two XML Schemas. The first XML Schema defines the language syntax and a basic vocabulary. The second XML schema is called the Data Dictionary. It provides the complete vocabulary with textual definitions and a lightweight formalisation of the vocabulary terms semantics as an XML Schema.

ODRL seems quite complete and generic enough to cope with such a complex domain. However, the problem is that it has such a rich structure that it is difficult to implement. It is rich in the context of XML languages and the "traditional" XML tools like DOM or XPATH. There are too many attributes, elements and complex types to deal with. They are counted in Table 3 for the two XML Schemas that compose ODRL.

Schema	EX-11	DD-11
Xsd:attribute	10	3
Xsd:complexType	15	2
Xsd:element	23	74
Total	127	

Table 3. Number of named XML Schema primitives in ODRL

For instance, consider looking for all constraints in a right expression that apply to how we can access the licensed content. This would require so many XPath queries as there are different ways to express constraints. ODRL defines 23 constraints: industry, interval, memory, network, printer, purpose, quality, etc. This amounts to lots of source code, difficult to develop and maintain because it

6 is very sensible to minor changes to the ODRL specification. Fortunately, there is a workaround hidden in the language definitions.

As we have said, there is the language syntax but also some semantics. The *substitutionGroup* relations among elements, and the extension/restriction base ones among *complexType*s, encode generalisation hierarchies that carry some lightweight, taxonomy-like, semantics.

For instance, all constraints in ODRL are defined as XML elements substituting the *o-ex:constraintElement*. The difficulty is that although XML Schemas provide this information, it remains hidden when working with instance documents of these XML Schemas.

Moreover, there are more complex semantics encoded in the textual definitions of the Rights Data Dictionary. They are needed each time a programmer is developing an ODRL application and thus they must be “manually” interpreted repeatedly.

Our objective is to exploit ODRL hidden semantics and to attach more complex formalisations that facilitate ODRL applications implementation. In order to make ODRL semantics explicit we use ontologies. In the Web context, ontologies are promoted by the Semantic Web initiative (Berners-Lee, T. 2001) as a tool for Web-wide semantics-enabled processing. We have taken the Semantic Web approach because it is naturally prepared for the Internet domain and thus we use web ontologies.

We will use OWL as the tool to formalise ODRL semantics. This formalisation will be accomplished in two phases. First, the lightweight semantics encoded in the ODRL XML Schemas will be translated to OWL ontologies that make them explicit. This is detailed in the next subsections.

Second, it is time for the data dictionary semantics informally written down as textual definitions. It is difficult to completely formalise them but even if the formalisation is incomplete, they will greatly facilitate ODRL applications development. A preliminary attempt in this direction is shown in section 3.1.5.

3.1.1. *Explicit ODRL XMLSchema semantics*

As we have said, XML Schemas define the ODRL language syntax but also some simple semantics. The *substitutionGroup* relations among elements

and the extension/restriction base ones among *complexType*s encode generalisation hierarchies.

There are many attempts to make XML metadata semantics explicit. Usually, they translate it to Semantic Web languages that facilitate the formalisation. Some of them just model the XML tree using the RDF primitives (Klein, M.C.A. 2002). Others concentrate on modelling the knowledge implicit in XML languages definitions, i.e. DTDs or the XML Schemas, using web ontology languages (Amann, B. 2002) (Cruz, I. 2004). Finally, there are attempts to encode XML semantics integrating RDF into XML documents (Lakshmanan, L. 2003) (Patel-Schneider, P.F. 2002).

However, none of them facilitates an extensive transfer of XML metadata to the Semantic Web in a general and transparent way. Their main problem is that the XML Schema implicit semantics are not made explicit when XML metadata instantiating this schemas is mapped. Therefore, they do not take profit from the XML semantics and produce RDF metadata almost as semantics-blind as the original XML. Alternatively, they capture this semantics but they use additional ad-hoc semantic constructs that produce less transparent metadata.

Therefore, we have chosen the ReDeFer⁵ methodology that combines a XML Schema to web ontology mapping, called XSD2OWL, with a transparent mapping from XML to RDF, XML2RDF. The ontologies generated by XSD2OWL are used during the XML to RDF mapping in order to generate semantic metadata that makes XML Schema semantics explicit. Both steps are detailed next and then their application to ODRL is shown.

3.1.2. *XSD2OWL Mapping*

The XML Schema to OWL mapping is responsible for capturing the schema implicit semantics. This semantics are determined by the combination of XML Schema constructs. The XSD2OWL mapping is based on translating this constructs to the OWL ones that best capture their semantics. These translations are shown in

Table 4.

The XSD2OWL mapping is quite transparent and captures a great part of XML Schema semantics. The same names used for XML constructs are used for OWL ones, although in the new namespace defined for the ontology. Therefore, it produces

OWL ontologies that make explicit the semantics of the corresponding XML Schemas. The only caveats are the implicit order conveyed by *xsd:sequence* and the exclusivity of *xsd:choice*.

XML Schema	OWL	SHARED INFORMAL SEMANTICS
element attribute	owl:DatatypeProperty ObjectProperty	Named relation between nodes or nodes and values
element @substitutionGroup	rdfs:subPropertyOf	Relation can appear in place of a more general one
element@type	rdfs:range	The relation range kind
complexType group attributeGroup	owl:Class	Relations and contextual restrictions package
complexType// element	owl:Restriction	Contextualised restriction of a relation
extension restriction @base	rdfs:subClassOf	Package concretises the base package
@maxOccurs @minOccurs	owl:maxCardinality minCardinality	Restrict the number of occurrences of a relation
sequence choice	owl:intersectionOf unionOf	Combination of relations in a context

Table 4. XML Schema to XSD2OWL translations

For the first problem, *owl:intersectionOf* does not retain its operands order. There is no clear solution that retains the great level of transparency that has been achieved. The use of RDF Lists might impose order but introduces ad-hoc constructs not present in the original metadata. Moreover, as it has been demonstrated in practise, implicit element ordering does not contribute much from a semantic point of view. For the second problem, *owl:unionOf* is an inclusive union, the solution is to use the *disjointness* OWL construct, *owl:disjointWith*, between all union operands in order to make it exclusive.

3.1.3. XML2RDF Mapping

Once all the metadata XML Schemas are available as OWL ontologies, it is time to map the XML metadata that instantiates them. The intention is to produce RDF metadata as transparently as possible. Therefore, a structure-mapping approach has been selected (Klein, M.C.A. 2002). It is also pos-

sible to take a model-mapping approach (Tous, R. 2005). Furthermore, XML model-mapping is based on representing the XML information set using semantic tools. This approach is better when XML metadata is semantically exploited for concrete purposes. However, when the objective is semantic metadata that can be easily integrated, it is better to take a more transparent approach.

Transparency is achieved in structure-mapping models because they only try to represent the XML metadata structure, i.e. a tree, using RDF. The RDF model is based on the graph so it is easy to model a tree using it. Moreover, we do not need to worry about the semantics loose produced by structure-mapping. We have formalised the underlying semantics into the corresponding ontologies and we will attach them to RDF metadata using the instantiation relation *rdf:type*.

The structure-mapping is based on translating XML metadata instances to RDF ones that instantiate the corresponding construct in OWL. The more basic translation is between relation instances, from *xsd:elements* and *xsd:attributes* to *rdf:Properties*. Concretely, *owl:ObjectProperties* for node to node relations and *owl:DatatypeProperties* for node to values relations. Values are kept during the translation as simple types and RDF blank nodes are introduced in the RDF model in order to serve as source and destination for properties. They will remain blank until they are enriched with semantic information. For the moment, the current state of the mapping is exemplified in Figure 4.

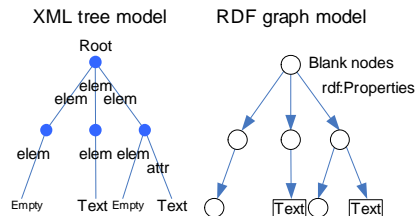

Figure 4. XML tree and resulting RDF graph models

The current RDF graph model contains all that we can obtain from the XML tree. It is already semantically enriched thanks to the *rdf:type* relation that connects each RDF property to the

8 *owl:ObjectProperty* or *owl:DatatypeProperty* it instantiates. It can be enriched further if the blank nodes are related to the *owl:Class* that defines the package of properties and associated restrictions they contain, i.e. the XML Schema complex types. This semantic decoration of the graph is formalised using *rdf:type* relations from blank nodes to the corresponding OWL classes.

At this point, we have obtained a semantics-enabled representation of the input metadata. The instantiation relations can now be used to apply OWL semantics to metadata.

3.1.4. Application to ODRL XML Schemas

First of all, the XSD2OWL mapping has been applied to the ODRL XML Schemas. ODRL schemas define a quite flat set of hierarchies for complex types and elements. They are translated to OWL classes and properties hierarchies. Once in OWL form, the previously hidden semantics can be exploited by OWL-aware tools that facilitate implementing ODRL applications.

Applications usually operate over ODRL instances, i.e. XML documents instantiating the XML Schemas. Therefore, in order to take profit from the just formalised semantic, it is necessary to map the XML instances to the semantic enriched form, i.e. to RDF metadata that instantiates the OWL ontologies just created.

The XML2RDF mapping resolves this. It receives the XML metadata for ODRL rights expressions and produces the RDF graph that models the corresponding XML tree. As it has been shown, the RDF graph is enriched with the XML Schema hidden semantics. Now, Semantic Web tools can easily put the ODRL XML Schemas semantics into practice.

For instance, we will retake the introduction problem about a query for retrieving the 23 different kinds of constraints affecting an ODRL rights expression. When we are working with the XML version, we need to consider 23 different XPath in order to retrieve all possible kinds of constraints. However, with the RDF version connected to the ODRL ontologies, a semantic query for *o-ex:constraintElement* will be automatically propagated in order to retrieve all the particular constraints defined as *substitutionGroups*.

As a result of the first step of ODRL semantics formalisation shown in this section, we have a methodology and some tools that allow us translating XML ODRL rights expressions into RDF-OWL.

The ODRL OWL ontologies formalise the XML Schema implicit semantics so they are available for Semantic Web tools in order to facilitate ODRL applications implementation. The ODRL Ontologies and metadata examples we have developed are available online⁶.

Moreover, the ontologies will serve as the anchor point where more detailed semantics will be attached during the second step of ODRL semantics formalisation. This process is detailed in the next section.

3.1.5. ODRL formalisation using IPROnto

The first step of ODRL semantics formalisation provides the lightweight semantics implicit in ODRL XML Schemas. Moreover, it provides the anchor points where we are going to attach the more detailed semantics formalised from the textual definitions of the Data Dictionary. The detailed semantics are written down as text so, in order to automatically extract them, natural language processing (NLP) methods could be used. However, we have not used NLP techniques because the Data Dictionary has short and ambiguous descriptions that are difficult to manage by automatic means.

We use a different approach. An accurate reading of the definitions together with the whole ODRL specification will be done, i.e. automatic means are not used. This reading is intended for interpreting ODRL semantics in the framework of IPROnto.

The ODRL ontologies are connected to IPROnto following the interpretation of the ODRL specification. Simple mappings are realised using OWL primitives for concept inclusion and equivalence (e.g. *subClassOf*, *subPropertyOf*, *equivalentClass*, *equivalentProperty* or *sameIndividualAs*).

However, the previous technique is only possible when we are mapping one concept from an ontology to one concept in the other ontology. When the conditions for the mapping are more complex, we are using semantic rules (Horrocks, I 2004). Rules are particularly useful when the mapping must

cope with a difference in the manner the concepts are structured in the mapped ontologies.

For instance, a contextualised description of an offer asset, see Figure 5, is transformed using the previous simple mappings in conjunction with the mapping rule (1) to the IPRonto-aware description shown in Figure 6.

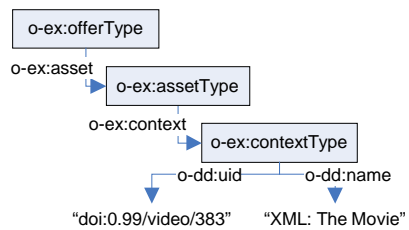

Figure 5. ODRL example in RDF graph form

$$\begin{aligned} & \text{o-ex:asset}(?x,?y) \wedge \text{o-ex:assetType}(?y) \\ & \wedge \text{o-ex:context}(?y,?z) \\ \Rightarrow & \text{ipro:Creation}(?z) \wedge \text{o-ex:asset}(?x,?z) \end{aligned} \quad (1)$$

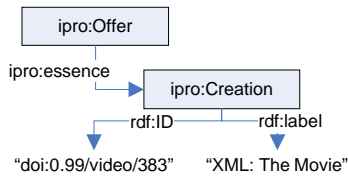

Figure 6. IPRonto-aware graph resulting from mapping Figure 5

3.2. MPEG-21 integration with IPRonto

MPEG-21 is another Digital Rights Management initiative. It is the MPEG standardisation framework for digital content management. As it has been introduced, MPEG's rights modelling part is divided into the Rights Expression Language (REL) and the Rights Data Dictionary (RDD). The REL part of MPEG-21 is, like ODRL, based on XML Schemas. It is even more complex than ODRL as shown in Table 5, where the attributes, elements and complex types are counted for the three main MPEG-21 XML Schemas. There are 330 components for 127 in ODRL.

For the XML Schema part of MPEG-21 REL, we use the same methodology than for ODRL. We

have produced one OWL ontology for each REL XML Schemas. However, this is not enough to put all REL hidden semantics into practice. That was enough with ODRL because it uses XML Schemas both for the language and dictionary definitions. However, the MPEG-21 dictionary (RDD) is not a XML Schema dictionary, it is an ad-hoc ontology. This poses additional difficulties to MPEG-21 applications development. The REL and the RDD are not integrated and RDD ontology requires specialised developments because it is not written using a common ontology language.

Schema	REL-R	REL-SX	REL-MX
xsd:attribute	9	3	1
xsd:complexType	56	35	28
xsd:element	78	84	36
Total	330		

Table 5. Named XML Schema primitives in MPEG-21 REL

For the XML Schema part of MPEG-21 REL, we use the same methodology than for ODRL. We have produced one OWL ontology for each REL XML Schema. However, this is not enough to put all REL hidden semantics into practice. That was enough with ODRL because it uses XML Schemas both for the language and dictionary definitions. However, the MPEG-21 dictionary (RDD) is not a XML Schema dictionary, but an ad-hoc ontology. This poses additional difficulties to MPEG-21 applications development. The REL and the RDD are not integrated, and RDD ontology requires specialised developments because it is not written using a common ontology language.

In order to make RDD easily operable and to integrate it with REL, the MPEG-21 RDD ontology is translated (Delgado, J. et al. 2004) to OWL. Once this is done, this ontology is connected to the semantic formalisation build up from the MPEG-21 REL XML Schemas. Consequently, semantic queries can also profit from the RDD ontology semantics.

For instance, the acts taxonomy in MPEG-21 RDD, see Figure 7, can be seamlessly integrated in order to facilitate license-checking implementation. Consider the scenario: we want to check if our set of licenses authorises us to uninstall a licensed program.

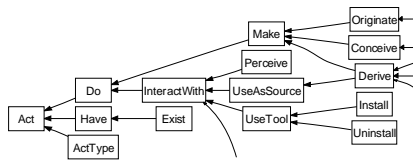

Figure 7. Portion of the acts taxonomy in MPEG-21 RDD

If we use XPath, there must be a path to look for licenses that grant the *uninstall* act, e.g. `“//r:license/r:grant/mx:uninstall”`. Moreover, as it is shown in the taxonomy, the *usetool* act is a generalisation of the *uninstall* act. Therefore, we must also check for licenses that grant us *usetool*, e.g. `“//r:license/r:grant/mx:uninstall”`. And successively, we should check for *interactwith*, *do* and *act*. All this must be done programmatically, the XPath queries are generated after we check the RDD ontology.

However, if we use semantic queries, the existence of a license that grants any of the acts that generalise *uninstall* implies that the license also states that the *uninstall* act is also granted. This is so because, by inference, the presence of the fact that relates the license to the granted act implies all the facts that relate the license to all the acts that specialise this act.

Therefore, it would suffice to check the semantic query `“//r:license/r:grant/mx:uninstall”`. If any of the more general acts were granted it would match. For instance, the XML fragment

- `/r:license/r:grant/dd:usetool`

implies the fragments

- `/r:license/r:grant/dd:install`
- `/r:license/r:grant/dd:uninstall`.

Moreover, all this is done in the same integrated semantic framework resulting from the connection of the REL XML Schemas ontologies and the OWL version of RDD⁷.

3.3. Additional benefits

The direct benefits of the ODRL and REL-RDD mappings to IPROnto are that a substantial part of their semantics are formalised. This might reduce ambiguities, or at least highlight possible ambiguous points. For instance, the OWL version of RDD

allowed detecting inconsistencies in the RDD specification (Barlas, C. 2005).

Moreover, there are new application development facilities. In addition to the semantic queries benefits shown before, other semantics-enabled tools can be used. One of the most promising tools is Description Logics (DL) (Pan, J.Z. 2004). OWL is based on DL so it can be directly fed into DL classifiers. Classifiers are specialised logic reasoners that guarantee computable results. DL classifiers are used with IPROnto in order to automatically check IP uses against the use patterns specified in IP agreements or offers. This facilitates checking if a particular use is allowed in the context of a set of licenses or finding an offer that enables it, once an agreement is reached.

DL classifiers can be directly reused so there is no need to develop ad-hoc applications to perform this function. Moreover, as they are completely OWL semantics aware, the IPROnto to ODRL and REL-RDD ontologies mappings enable their use in order to check uses against ODRL and REL licenses, even if they are in XML form. XML ODRL and REL licenses can be mapped to RDF using XML2RDF and then, through mappings, get connected to the IPROnto semantic framework.

The use of DL classifiers for digital rights management can be exemplified with the following scenario:

1. The initial situation is: “USER1 is trying to access a given video stream from a given streaming server at 9:30:10 UTC on 2005-04-10”. The streaming server implements digital rights management so it inquires the license manager if the current usage instance is permitted. In order to do that, the streamer models this usage using IPROnto, see Figure 8, and sends it to the license manager, e.g. as a RDF/XML serialisation.
2. The license manager contains licenses modelled using IPROnto, among others the one shown in Figure 9. This license defines an usage pattern for a creation located at the streaming server that can be performed by a class of agents for a given period of time starting on a given date. Moreover, the license manager has additional metadata stating that USER1 is an instance of the “O=i2CAT,C=ES” class.

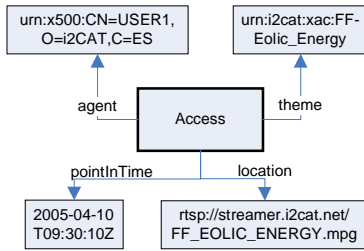

Figure 8. Usage instance modelled by the streaming server

3. The license manager checks if there is any license that grants a usage pattern that subsumes the usage instance. This can be performed easily and efficiently using a DL classifier. However, there are some problems that should be resolved before. First, the usage patterns have a condition property that should be ignored during subsumption computation. Second, the usage patterns define time intervals using a start time and duration, while the usage instance defines a time point. In order to check if the time point is included in the time interval, we must use a DL classifier capable of dealing with custom datatypes reasoning (Pan, J.Z. 2005). Then, the time interval is translated to a real interval ($\text{pointInTime} \geq [20050401]^{real} \wedge \leq [20060401]^{real}$) and the time point to a real ($\text{pointInTime} = [20050410.093010]^{real}$).

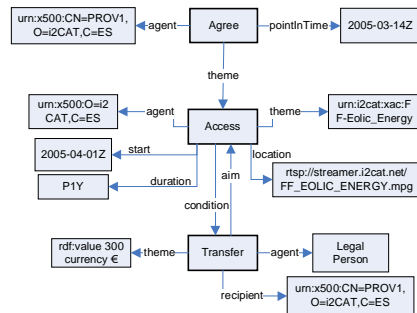

Figure 9. Use license model defining permitted usage pattern and condition

4. After applying the previous adaptations, subsumption is computed. The usage might be classified in one or more usage patterns. In this case it is tested if the usage pattern is the theme

of an agree. Then, if there is an instance of the condition, i.e. it is satisfied, the license manager tells the streaming server that the use is authorised. Otherwise, the use is not authorised.

This is a simple scenario for illustrative purposes. It could be extended in many ways. For instance, if the usage pattern is the theme of an offer, another possibility is to recommend the user the possibility to negotiate it in order to arrive to a new agreement. From this point, it can be connected to negotiation architectures previously designed by in our research group (Delgado, J. 2002) (Gil, R. 2003).

4. Conclusions

IPRonto is not an isolated ontology and it has not been built from scratch, since some international projects have been chosen to begin with its construction. It means that this ontology is based on solid roots but not constrained by them. It can be related to upper ontologies as IEEE SUMO, DOLCE and LRI-Core. Methontology has driven IPRonto development. Some mappings have been proposed to relate our ontology to other initiatives as ODRL and MPEG-21 REL, semantic rules are used when the conditions increase in complexity. IPRonto characteristics allow Rights Expression Languages (ODRL and MPEG-21 REL) to be formalised and made interoperable. Therefore, they can even be made independent from their dictionaries.

Finally, all these ideas and tools are being integrated in wider projects that are fitted to the aim of IPRonto to integrate different standards, which include content management and digital rights management based on a Semantic Web based information system (García, R. 2004). This infrastructure allows the use of semantic queries and DL reasoning for license searching and checking to be tested inside the project.

5. REFERENCES

Amann, B.; Beer, C.; Fundulak, I. & Scholl, M. (2002), Ontology-Based Integration of XML Web Resources, *in* 'Proceedings of the 1st International Semantic Web Conference (ISWC 2002)', Springer-Verlag, pp. 117-131.
 Barlas, C. (1998), 'The IMPRIMATUR Project', *in* 'European Audiovisual Conference'.

Bernd
 Vrie
 Ror
 Id
 Lee
 es,
 Joh
 Zeli
 nikk
 -
 Mer
 ng
 the
 fust

- Barlas, C. & Rust, G. (2005), 'Rights Data Dictionary, Technical Corrigendum 1', ISO/IEC JTC 1/SC 29/WG 11.
- Berners-Lee, T.; Hendler, J. & Lassila, O. (2001), 'The Semantic Web', *Scientific American* 284(5), 34-43.
- Breuker, J. (2004), Constructing a legal core ontology: LRI-Core, in 'Workshop on Ontologies and their Applications'.
- Cruz, I.; Xiao, H. & Hsu, F. (2004), An Ontology-based Framework for XML Semantic Integration, in 'Eighth International Database Engineering and Applications Symposium'.
- Delgado, J.; Gallego, I.; Garcia, R.; Gil, R.; Peig, E. & Tous, R. (2001), 'Intellectual Property Rights Ontology (IPROnto)'(M7675), ISO/IEC JTC1/SC29/WG11, Technical report, Moving Picture Experts Group.
- Delgado, J.; Gallego, I.; Garcia, R. & Gil, R. (2002), IPROnto: Intellectual Property Rights Ontology, in 'Ext. Poster Abstracts in Proc. International Semantic Web Conference'.
- Delgado, J.; Gallego, I.; García, R. & Gil, R. (2002b), An architecture for negotiation with mobile agents, in A. Karmouch; T. Magedanz & J. Delgado (ed.) 'Mobile Agents for Telecommunication Applications: 4th International Workshop', Springer-Verlag, pp. 21-31.
- Fenández-López, M.; Gómez-Pérez, A. & Juristo, N. (1997), Methontology: from ontological art towards ontological engineering, in 'Proc. Symposium on Ontological Engineering of AAAI'.
- Fernández-López, M. (1999), Overview of Methodologies for Building Ontologies, in 'Proc. Workshop on Ontologies and Problem-Solving Methods'.
- Gallego, I.; Delgado, J. & García, R. (2000), Use of Mobile Agents for IPR Management and Negotiation, in 'Proc. Mobile Agents for Telecommunication Applications', Springer-Verlag, pp. 205-213.
- Gangemi, A.; Guarino, N.; Masolo, C.; Oltramari, A. & Schneider, L. (2002), Sweetening Ontologies with DOLCE, in A. Gómez-Pérez & V.R. Benjamins, ed., 'Knowledge Engineering and Knowledge Management. Ontologies and the Semantic Web, 13th International Conference, EKAW 2002', Springer-Verlag, pp. 166-181.
- García, R.; Gil, R. & Delgado, J. (2004), Intellectual Property Rights Management using a Semantic Web Information System, in R. Meersman & Z. Tari (ed.) 'OTM Confederated International Conferences, CoopIS, DOA, and ODBASE 2004', Springer-Verlag, pp. 689-704.
- Gil, R.; García, R. & Delgado, J. (2003), Delivery context negotiated by mobile agents using CC/PP, in 'Mobile Agents for Telecom Applications, (MATA'03)', Springer-Verlag, pp. 99-110.
- Hendler, J. (2001), 'Agents and the Semantic Web', *IEEE Intelligent Systems* 16(2).
- Horrocks, I.; Patel-Schneider, P.F.; Boley, H.; Tabet, S.; Grosz, B. & Dean, M. (2004), 'SWRL: A Semantic Web Rule Language Combining OWL and RuleML', Technical report, DARPA DAML Program.
- Hunter, J. (2003), 'Enhancing the Semantic Interoperability of Multimedia through a Core Ontology', *IEEE Transactions on Circuits and Systems for Video Technology, Special Issue on Conceptual and Dynamical Aspects of Multimedia Content Description* 13(1), 49-58.
- Iannella, R. (2002), 'Open Digital Rights Language (ODRL), Version 1.1', Technical report, World Wide Web Consortium.
- Klein, M. (2002), Interpreting XML Documents via an RDF Schema Ontology, in 'Proceedings of the 13th International Workshop on Database and Expert Systems Applications (DEXA 2002)', pp. 889-894.
- Lakshmanan, L. & Sadri, F. (2003), Interoperability on XML Data, in 'Proceedings of the 2nd International Semantic Web Conference (ISWC 03)', Springer-Verlag.
- Pan, J.Z. (2004), 'Description Logics: Reasoning Support for the Semantic Web', PhD thesis, School of Computer Science, The University of Manchester.
- Pan, J.Z. & Horrocks, I. (2005), OWL-Eu: Adding Customised Datatypes into OWL, in 'Proc. of Second European Semantic Web Conference (ESWC 2005)'.
- Patel-Schneider, P. & Simeon, J. (2002), The Yin/Yang web: XML syntax and RDF semantics, in 'Proceedings of the 11th International World Wide Web Conference (WWW02)', pp. 443-453.

Pease, A.; Niles, I. & Li, J. (2002), The Suggested Upper Merged Ontology: A Large Ontology for the Semantic Web and its Applications, in A. Pease, ed., 'Ontologies and the Semantic Web, Papers from the AAAI Workshop', AAAI Press.

Rust, G. & Barlas, C. (2005), 'The MPEG-21 Rights Data Dictionary', *IEEE Transactions on Multimedia* 7(2).

Rust, G. & Bide, M. (2000), 'The <indecs> meta-data framework: Principles, model and data dictionary' (WP1a-006-2.0), Technical report, Indecs Framework Ltd, © Indecs Framework Ltd.

Sowa, J.F. (2000), *Knowledge Representation. Logical, philosophical and computational foundations*, Brooks Cole Publishing Co.

Tous, R. & Delgado, J. (2005), Using OWL for Querying an XML/RDF Syntax, in 'Poster at WWW05'.

Walle, R.v.d. (2005), *The MPEG-21 Book*, John Wiley & Sons, Chichester.

Wang, X.; DeMartini, T.; Wragg, B. & Paramasivam, M. (2005), 'The MPEG-21 Rights Expression Language', *IEEE Transactions on Multimedia* 7(2).

Endnotes

¹ Distributed Multimedia Applications Group - <http://dmag.upf.edu>

² WIPO - <http://www.wipo.org>

³ Intellectual Property Rights ONTOlogy - <http://dmag.upf.es/ontologies/ipronto>

⁴ MPEG-21 Rights Data Dictionary and Rights Expression Language call for proposals, http://www.chiariglione.org/mpeg/working_documents/mpeg-21/requirements/RDD&REL_requirements.zip

⁵ ReDeFer, <http://rhizomik.upf.edu/redefer>

⁶ ODRL Ontologies, <http://dmag.upf.edu/ontologies/odrlontos>

⁷ MPEG-21 REL and RDD Ontologies, <http://dmag.upf.edu/ontologies/mpeg21ontos>